

3
D
C
A
D
M
A
S
T
E
R
P
A
R
T
N
A
M
E
-
A
V
-
P
l
a
t
e
-
A
s
s
e
m
b
l
y

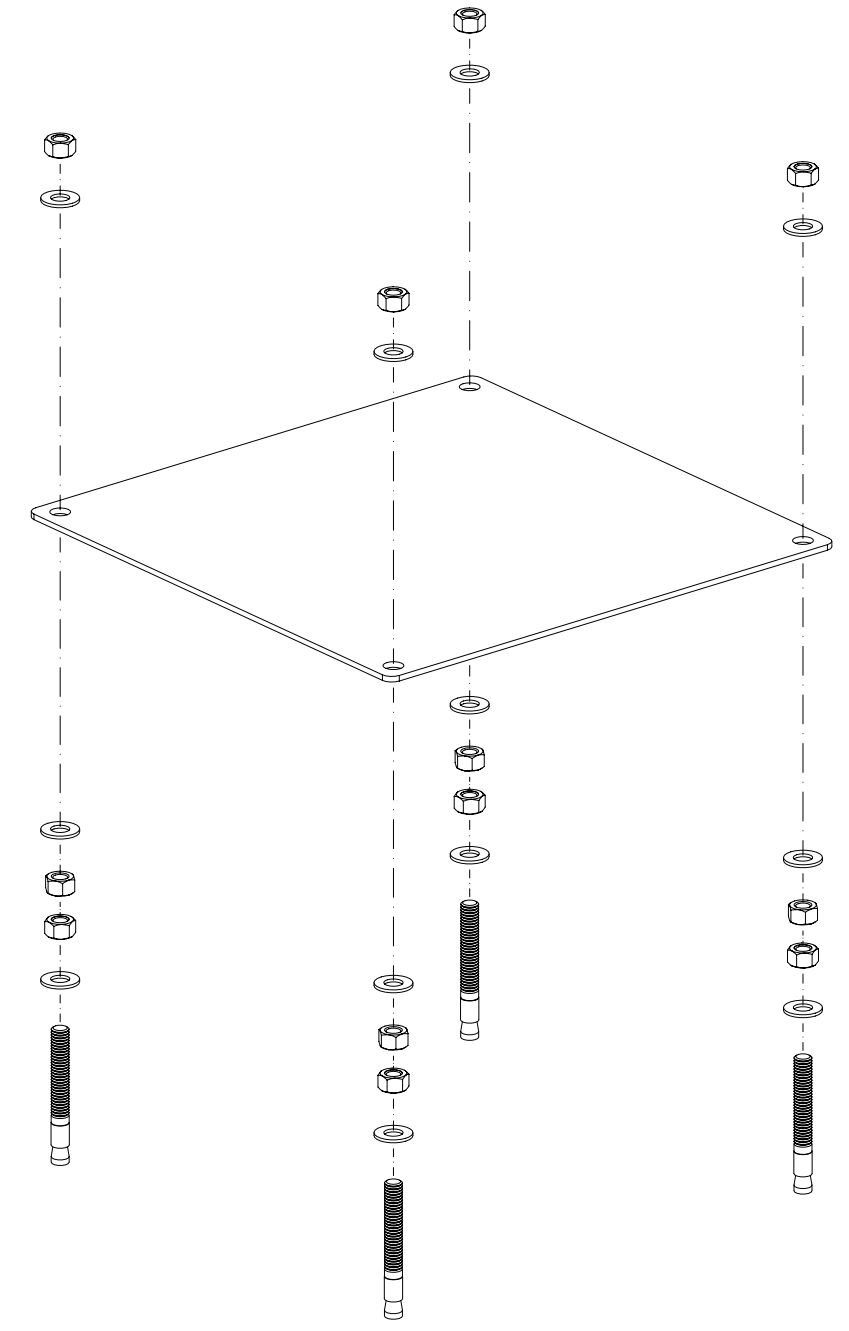
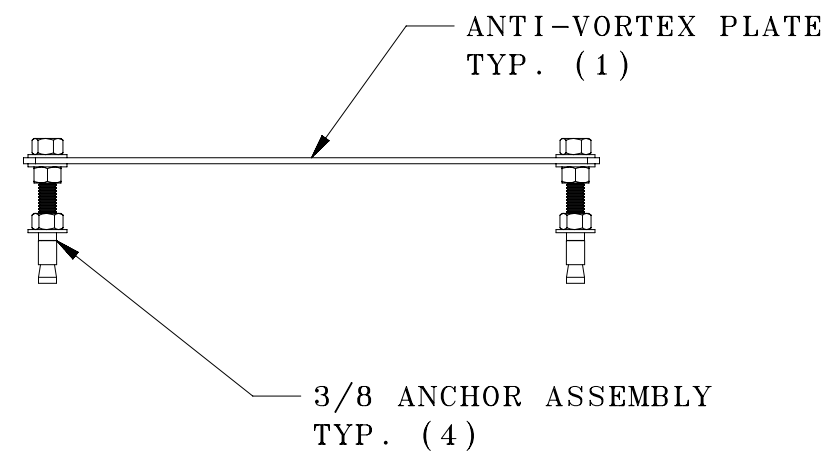
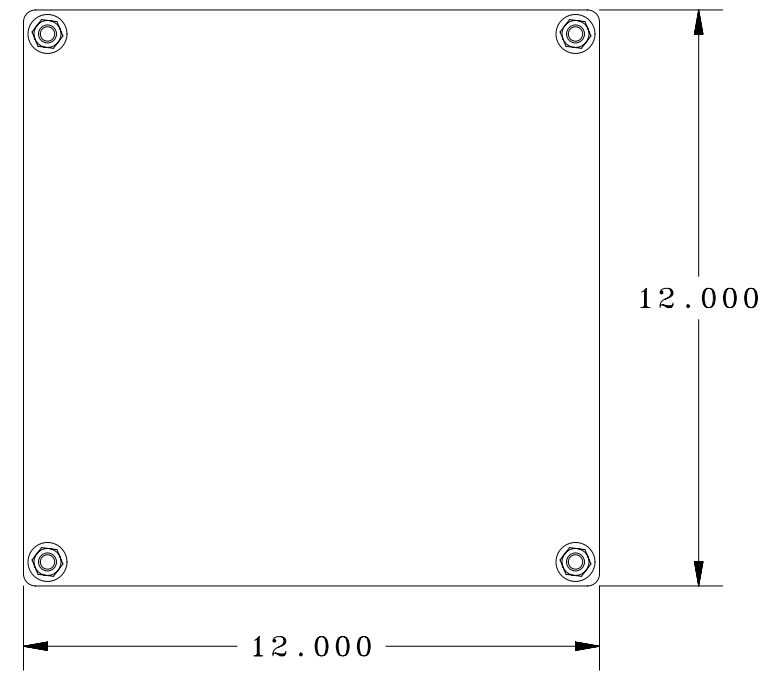
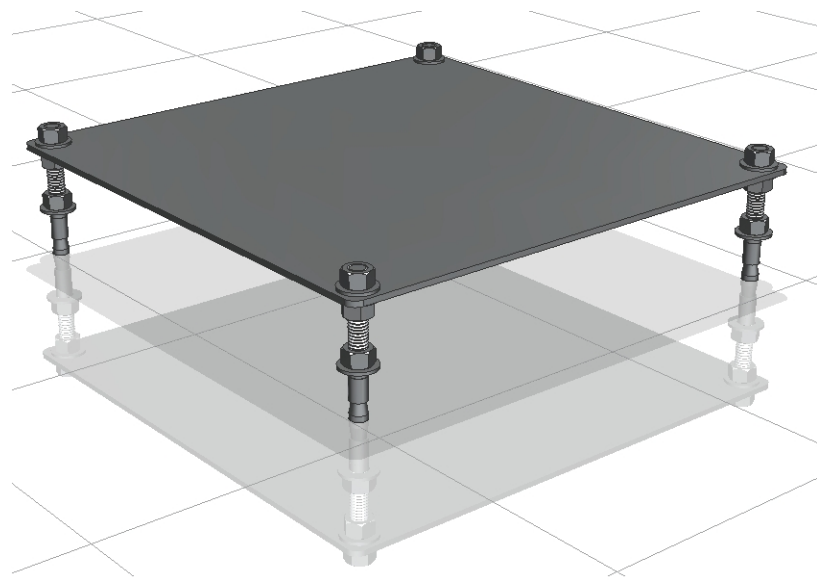

- NOTE**
1. ALL DIMENSIONS IN INCHES
 2. COMPONENTS MATERIAL TO BE TYPE 304 STAINLESS STEEL
 3. BREAK ALL SHARP EDGES
 4. RADIUS ALL SHARP CORNERS OF FINISHED COMPONENT

	FOUNTAIN SUPPLY COMPANY ENGINEERING DEPARTMENT SANTA CLARITA, CALIFORNIA 91350 Ph: 661-254-4448 Fax: 661-254-5777	
	TITLE Anti-Vortex Plate	
SIZE DRG NO. B AV-Plate_Assembly_dwg1	REV A	
SCALE 1:4	SHEET 1 OF 1	